



VIKING 4 TONNE JACKING BEAM WITH 1.4M EXTENDING ARMS

MODEL NO: **SJBEX4000S**

Thank you for purchasing a Sealey product. Manufactured to a high standard, this product will, if used according to these instructions, and properly maintained, give you years of trouble free performance.

IMPORTANT: PLEASE READ THESE INSTRUCTIONS CAREFULLY. NOTE THE SAFE OPERATIONAL REQUIREMENTS, WARNINGS & CAUTIONS. USE THE PRODUCT CORRECTLY AND WITH CARE FOR THE PURPOSE FOR WHICH IT IS INTENDED. FAILURE TO DO SO MAY CAUSE DAMAGE AND/OR PERSONAL INJURY AND WILL INVALIDATE THE WARRANTY. KEEP THESE INSTRUCTIONS SAFE FOR FUTURE USE.



Refer to instruction manual



Wear eye protection



Wear protective clothing



Wear safety footwear



1. SAFETY

- ✓ Ensure the beam is in sound condition and good working order. Take action for immediate repair or replacement of damaged parts. Use genuine parts only. The use of improper parts may be dangerous and will invalidate the warranty.
- ✓ Inspect the beam before each use. **DO NOT** use the beam if it is damaged, altered, modified, in poor condition, leaking hydraulic fluid, or unstable due to missing parts.
- ✗ **DO NOT** alter or modify this beam, including the safety valve, in any way. **DO NOT** load the beam beyond its rated capacity. **DO NOT** operate the beam if damaged.
- ✗ **DO NOT** allow untrained persons to operate the beam.
- ✗ **DO NOT** use the beam for purposes other than that for which it is intended.
- ✓ Before installing and using the product, please carefully read and fully understand the contents of these instructions, and make sure that every operator of the product has read and understood the contents, and put the instruction in a safe place for future reference.
- ✓ The product can be used between -20° and +50°C.
- ✗ **DO NOT** use for the lifting of persons.
- ✓ Use the beam only for its intended purpose.
- ✓ Consult the vehicle manufacturer for the correct lifting locations.
- ✓ Make sure the vehicle is in park and the handbrake is on before attempting to raise the vehicle.
- ✓ Only use the saddles provided with the jacking beam.
- ✓ Be sure setup is stable and secure before lifting. Be careful of pinch points.
- ✓ This is a lifting device only. Make sure the load is central on saddles before lifting.
- ✓ The beam can only be used to lift one end of the vehicle.
- ✓ Ensure that there are no persons or obstructions beneath the vehicle before lowering. Always lower load slowly and carefully.
- ✓ Please check the spillage of oil before use, if you notice a spillage of oil, stop using the product and repair immediately.
- ✓ If the product can not be lowered as wished, the vehicle must be secured by suitable means against unintended lowering. Get a new suitable product, with which you can lift the vehicle, so that the defective product can be repaired or removed and changed. If you are unsure, please ask for professional help.
- ✓ The operator **MUST** watch the lifting device and the load during all movements.
- ✗ **DO NOT** work under the raised load until it is secured by suitable means.
- ✓ Product safety markings need to be inspected before use and be maintained in as new condition. Contact Sealey for replacements if damaged.
- ✓ This product must be maintained and repaired in accordance with the manufacturers instructions. Such maintenance and repair shall be carried out by qualified persons.
- ✓ This jacking beam is only to be mounted on lifts approved by the lift manufacturer for mounting of jacking beams. Be aware that not all lifts are approved. Rated beam capacity must be max. 2/3 of vehicle lift capacity.
- ✓ Mount the jacking beam with adequate support arms on horizontal, parallel and solid rails and secure arms before use.
- ✓ Check before each lift, that the support arms are correctly placed on rail of lift or pit edge.
- ✓ Always lower the jacking beam to the nearest safety stop immediately - or use axle stands for support before working on vehicle.
- ✗ **DO NOT** overload, for instance due to sudden external overload can cause damage or failure of the jacking beam.
- ✓ During lifting make sure that the saddles cannot slide.
- ✓ Gravity of load must always be placed centrally.
- ✓ The 2 extension arms must only be used simultaneously.
- ☐ **WARNING!** Failure to heed these precautions may result in loss of load, damage to beam and/or personal injury.

2. INTRODUCTION

Jacking beam lifts load with compressed air. Fully certified and approved to comply with MOT requirements. Wide lift configuration meets MOT recommendation for lifting on jacking point. This item is heavy. Extra assistance must be provided at the delivery point to help its safe delivery.

3. SPECIFICATION

Model No:	SJBEX4000S
Air Pressure:	109-174psi
Beam Lift:	250mm
Capacity:	4000kg
Load Arm Reach:	680-1420mm
Support Arm Reach:	855-1275mm

Compatible Lifting & Support Accessories:

- SJBEX.A01 - Bearing Mounts for Viking Jacking Beams
- SJBEX.A02 - Rubber Support Block for Viking Jacking Beams 60mm
- SJBEX.A03 - Slotted Rubber Support Block for Viking Jacking Beams 80mm
- SJBEX.A04 - V-Adaptor for Viking Jacking Beams

4. ASSEMBLY

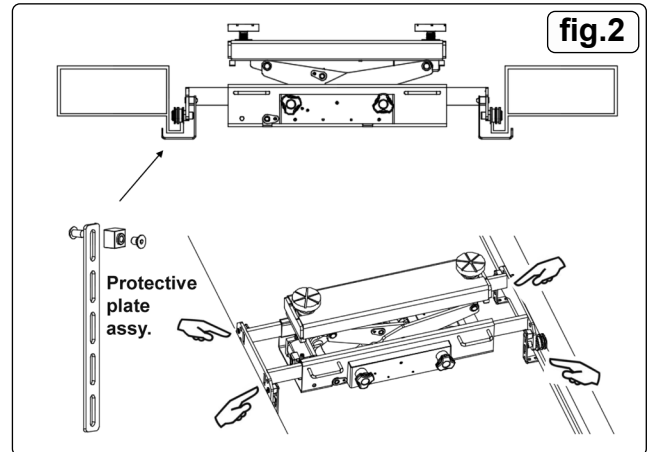
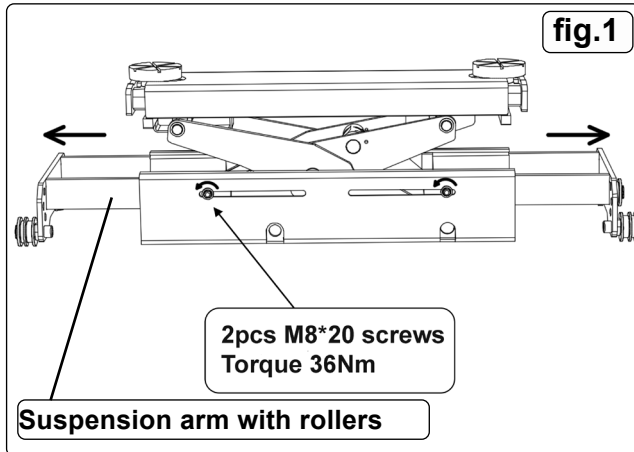

NOTE: SJBEX4000S is supplied with bearings. Diagrams in this manual are for reference only.

- 4.1. Extend arms to correct width and secure as per fig.1.
- 4.2. **SECURE JACKING BEAM WITH PROTECTIVE PLATE ASSEMBLY FIG.2**
- 4.2.1. Protective plate assembly needs to be accurately bent to provide a means to prevent the product tipping if using on a ramp. Refer to fig.2 top image.

5. OPERATION

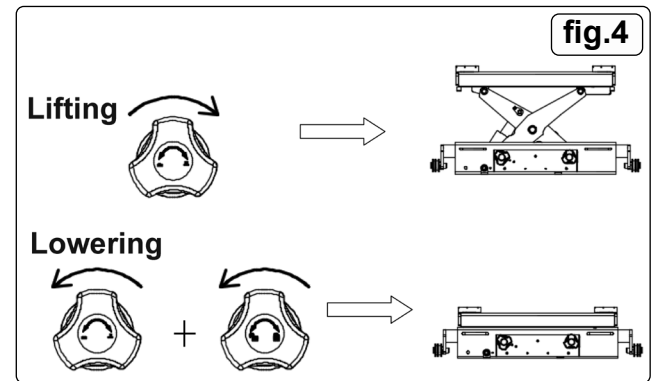
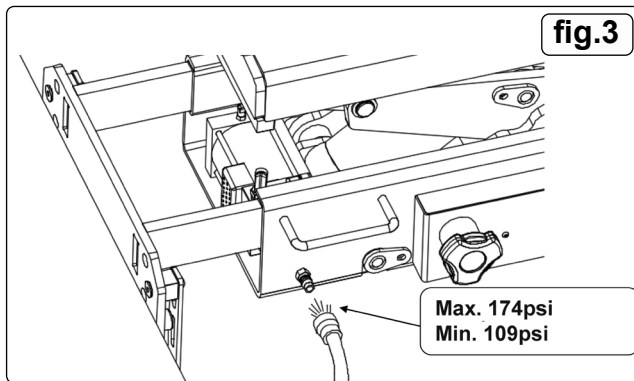

- 5.1. Connect to air supply as shown in fig.3.
- 5.2. **LIFTING AND LOWERING FIG.4.**
- 5.2.1. Ensure that all of Safety Section 1 are understood and adhered to before using the product.
- 5.2.2. Lowering requires both knobs to be turned anticlockwise.

6. MAINTENANCE

NOTE: Only fully qualified personnel should attempt maintenance or repairs.

- 6.1. When not in use, the beam should be stored in the lowest position, to minimise corrosion.
- 6.2. Keep the beam clean and lubricate all moving parts on a regular basis.
- ❑ **WARNING: DO NOT** use brake fluid, or any fluid other than a good quality jack oil, such as SEALEY HYDRAULIC JACK OIL, as this may cause serious damage to the jack and will invalidate the warranty.
- 6.3. To check on fluid level and to top up, jack the beam up so that the oil plug (see fig.5) can be accessed and removed.
- 6.4. The level should be just below the vent, top up as necessary and
- ✖ **DO NOT** overfill as this will affect the smooth operation of the beam. Refer to fig.6 for hydraulic oil capacity. Replace the plug.
- 6.5. Before each use check for broken, cracked, bent, or loose parts, or any visible damage to pump, saddles, lifting arms, frame and all parts including nuts, bolts, pins and other fasteners.
- 6.6. Check for oil leaks (fig.7). If any suspect item is found, remove beam from service and take action to remedy the problem.
- ✖ **DO NOT** use the beam if it is believed to have been subjected to abnormal load or shock load. Inspect and take appropriate action.
- 6.7. Periodically check the pump piston and the ram for signs of corrosion. Clean exposed areas with a clean oiled cloth.

N.B.: NO RESPONSIBILITY IS ACCEPTED FOR INCORRECT USE OF THIS PRODUCT.

Hydraulic products are only repaired by local service agents. We have service/repair agents in all parts of the UK.

DO NOT RETURN JACKS TO US. Please telephone us on 01284 757500 to obtain the address and phone number of your local agent. If jack is under guarantee you can also contact your local stockist.

6.8. DE-COMMISSIONING

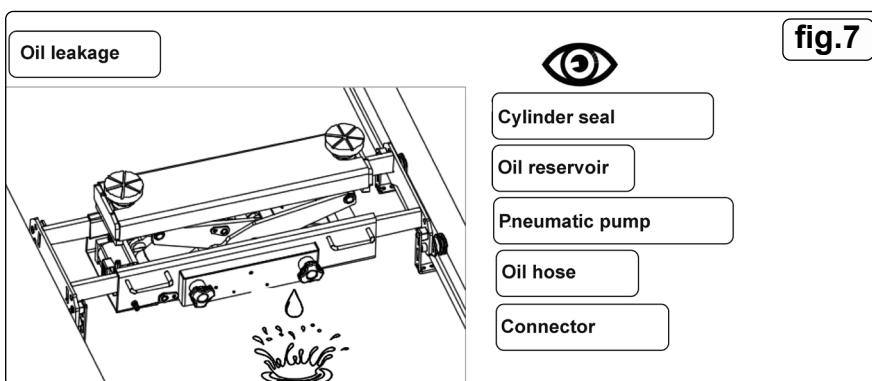
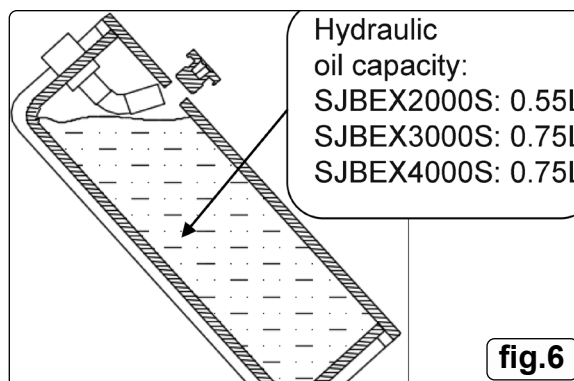
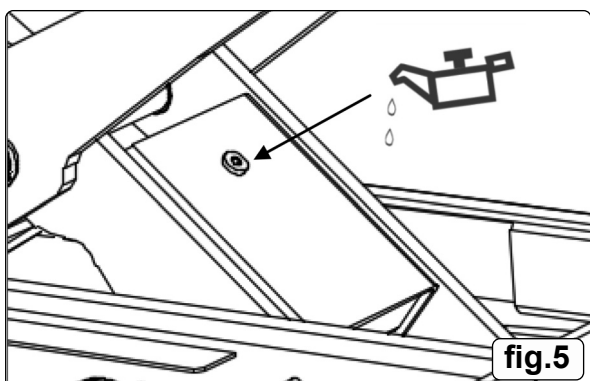

6.8.1. If the beam eventually becomes unserviceable, draw off the oil into an approved container and dispose of the jack and the oil according to local regulations.



 **ENVIRONMENT PROTECTION**
Recycle unwanted materials instead of disposing of them as waste. All tools, accessories and packaging should be sorted, taken to a recycling centre and disposed of in a manner which is compatible with the environment. When the product becomes completely unserviceable and requires disposal, drain any fluids (if applicable) into approved containers and dispose of the product and fluids according to local regulations.



Note: It is our policy to continually improve products and as such we reserve the right to alter data, specifications and component parts without prior notice.
Important: No Liability is accepted for incorrect use of this product.
Warranty: Guarantee is 24 months from purchase date, proof of which is required for any claim.

Sealey Group, Kempson Way, Suffolk Business Park, Bury St Edmunds, Suffolk. IP32 7AR
 **01284 757500**  **sales@sealey.co.uk**  **www.sealey.co.uk**